

Tu.4.H.3

Photonic Interconnect Technologies for Data Center and HPC in the EU Project PhoxTroT

Tolga Tekin and Dimitris Apostolopoulos



tolga.tekin@izm.fraunhofer.de



National TU of Athens

apostold@mail.ntua.gr

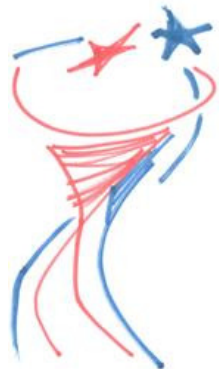

© PhoxTroT

PhoxTroT

**Photonics for High-Performance, Low-Cost & Low-Energy
Data Centers, High Performance Computing Systems:
Terabit/s Optical Interconnect Technologies for On-Board,
Board-to-Board, Rack-to-Rack data links**



The Cloud



- Annual global data center IP traffic will reach 6.6 zettabytes by the end of 2016. By 2016, global data center IP traffic will reach 554 exabytes per month (up from 146 exabytes per month in 2011)
- By 2016, nearly two-thirds of all workloads will be processed in the cloud

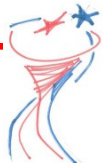

Traffic Statistics

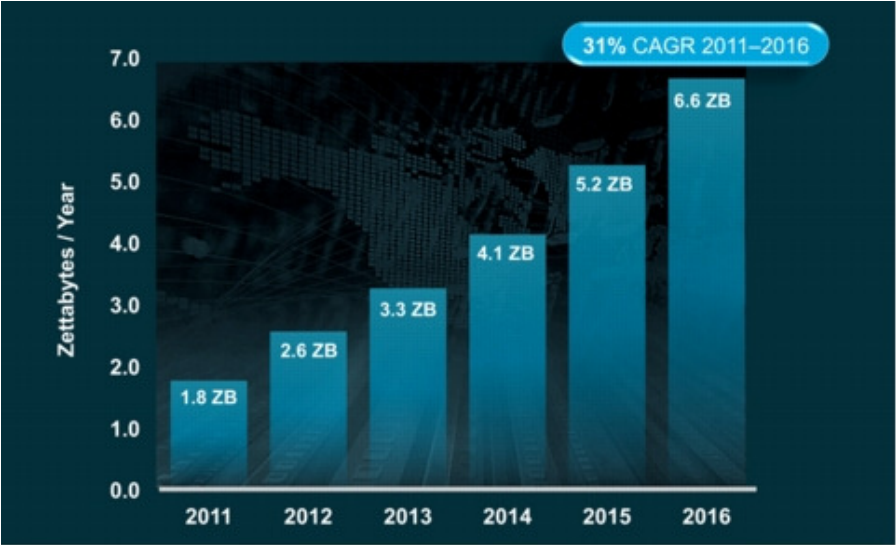

- ❑ Internet is forecast to reach the zettabyte era in 2016, but the data center has already entered the zettabyte era
- ❑ Expected to reach 6.6 zettabytes in 2016

Traffic change 2011-2016

- DC to DC: 32%
- DC to user: 31%
- Within DC: 30%

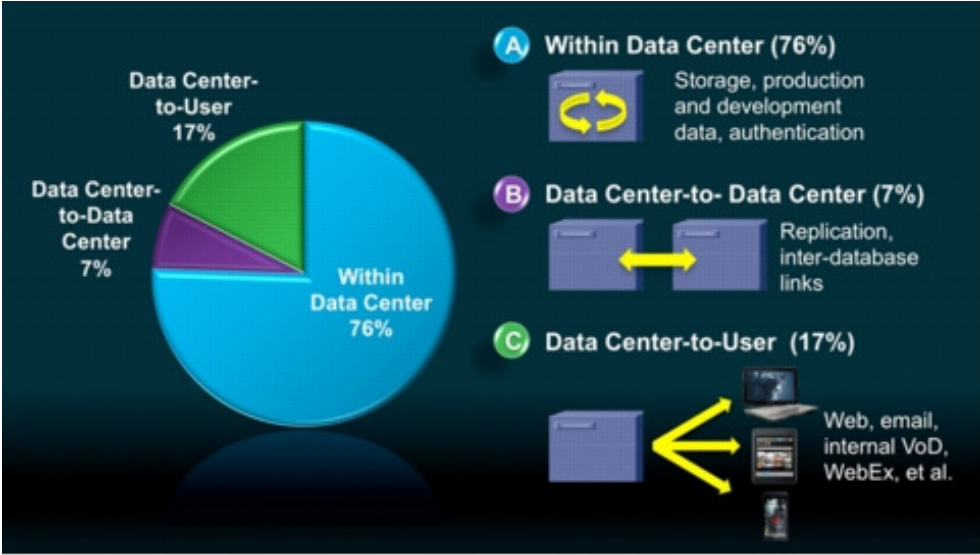

Source: Cisco Global Cloud Index



Challenges



- Data center size
 - From DC to DF
- DC became huge
- Increased cabling
 - Space and cost
- Larger number of intra-datacenter interconnections
- Bandwidth
- Power, cabling and bandwidth
- power consumption

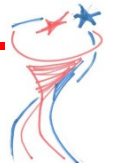

Optical Interconnection

- ❑ Electrical Buses become increasingly difficult at high data rates.
 - ❑ Increasing losses & cross-talk
 - ❑ Frequency resonant affects
- ❑ Optical data transmission is easier.
 - ❑ Much lower loss, esp. at higher data rates
 - ❑ Cable bulk, connector size, EMI...
- ❑ $BW * Distance > electrical$
- ❑ Power efficiency compared to copper solutions
- ✓ Significant progress has been done already but
 - ❑ Per technology platform research
 - ❑ Focus is on pieces of the complete puzzle
 - ❑ In most cases applications is not the driving force



Enter PhoxTroT

PhoxTroT is a large-scale European research effort focusing on

- ★ high-performance,
- ★ low-energy,
- ★ low-cost,
- ★ small-size

Optical interconnects across the whole data center ecosystem:

- ★ on-board,
- ★ board-to-board and
- ★ rack-to-rack.



Objectives

- ★ Generic building block that can be used for a broad range of applications, **extending performance beyond Tb/s** and **reducing energy by more than 50%**.
- ★ A unified **integration/packaging methodology** as a cost/energy-reduction factor for board-adaptable **3D SiP** transceiver and router optochip fabrication.
- ★ The whole "food-chain" of low-cost and low-energy interconnect technologies concluding to 3 fully functional prototype systems:
 - ★ an **>1Tb/s throughput** optical PCB and **>50% reduced energy** requirements
 - ★ a **high-end >2Tb/s throughput** optical backplane for board-to-board interconnection and
 - ★ a **1.28Tb/s** Active Optical Cable that **reduces power** requirements by **>70%**.

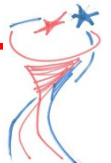

Holistic Approach

PhoxTroT tackles optical interconnects in a holistic way, **synergizing** the different technology platforms in order to deploy the optimal "**mix&match**" technology and tailor this to each interconnect layer.

PCBs	Polymers	Glass
Interfaces	Glass	Plasmonics
PICs	Si Photonics	
Transceivers	III-V	CMOS electronics
Switches & Routers	Si Photonics	CMOS electronics

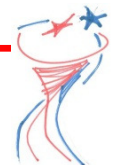

Ecosystem

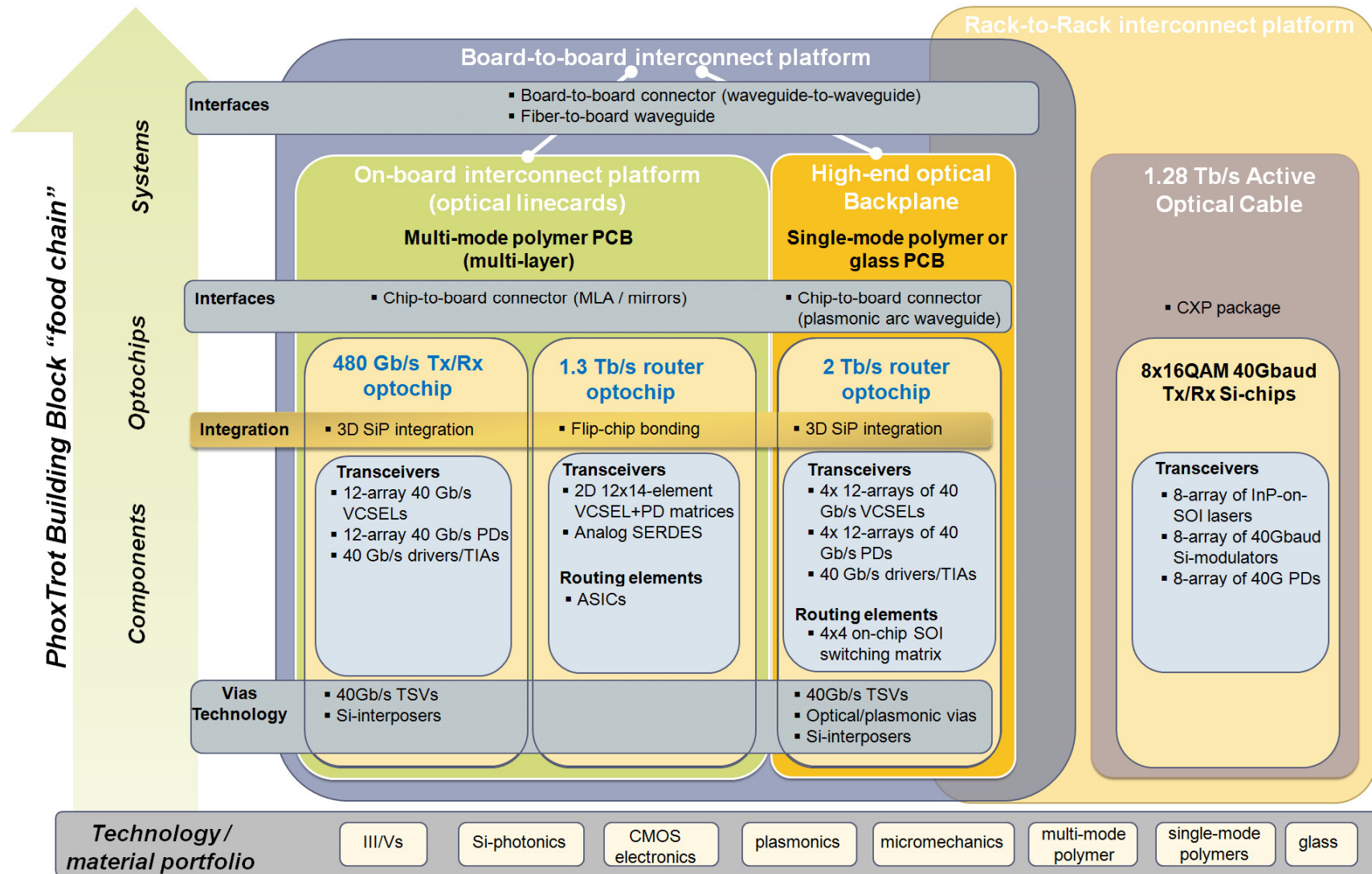

On-Board, Multi-Mode Optical Interconnection Technologies

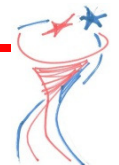
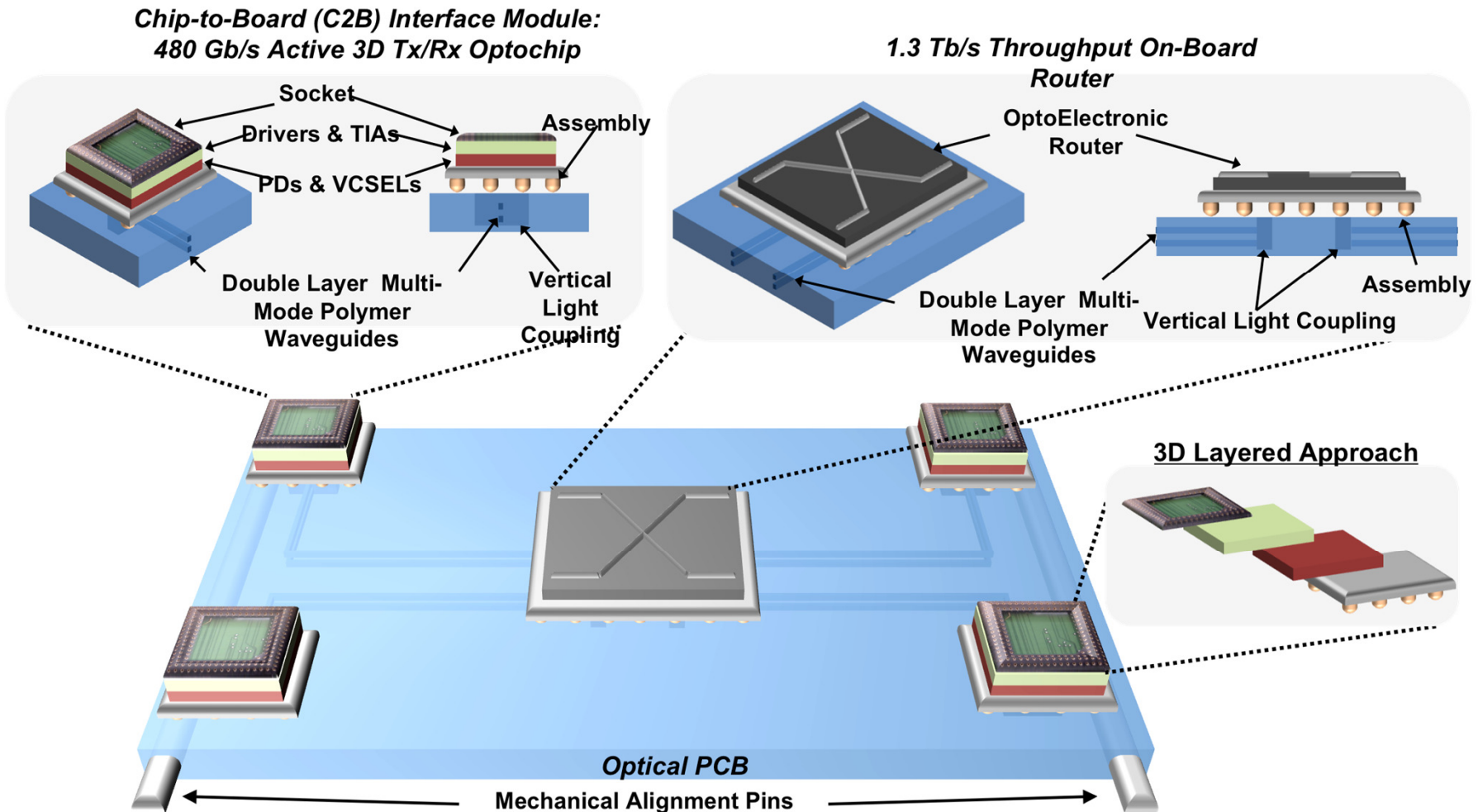

Multi-Mode Demonstration Scenario

★ DATA CENTRE SUBSYSTEM ADAPTATION

- ★ SBB form factor allowing deployment in data storage enclosure
- ★ Data storage system front end
- ★ SAS controller hardware
- ★ FPGA for protocol conversion
- ★ Optical waveguide interconnection
- ★ Electrical and optical backplane compatibility

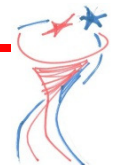
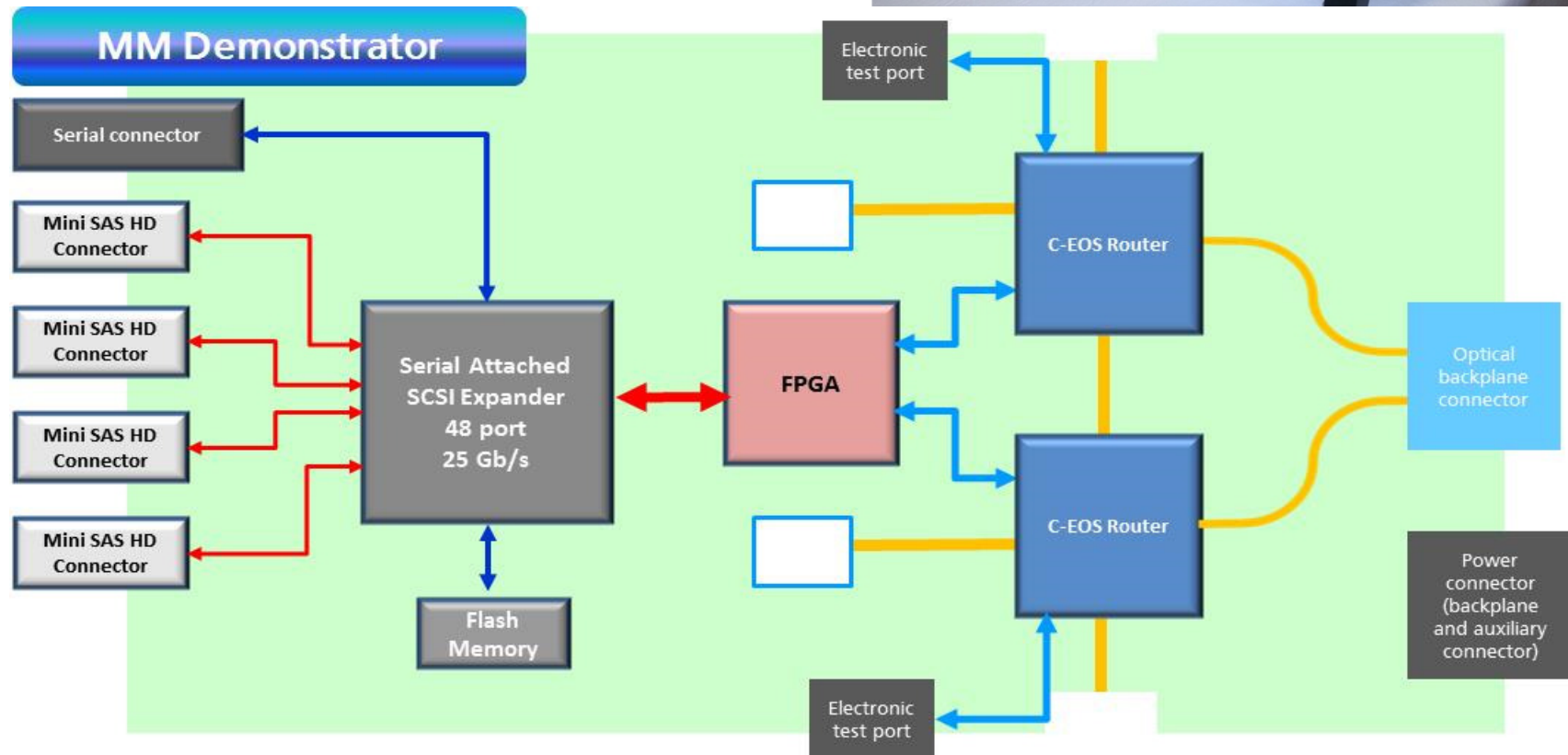

Multi-Mode Polymer Waveguide PCB

- ★ PhoxTroT on-board platform designs
 - ★ Dual layer polymer based PCB with embedded optical waveguide
 - ★ C2B interfaces
 - ★ Two optoelectronic routers optically interconnected c

PHOXTROT51_1

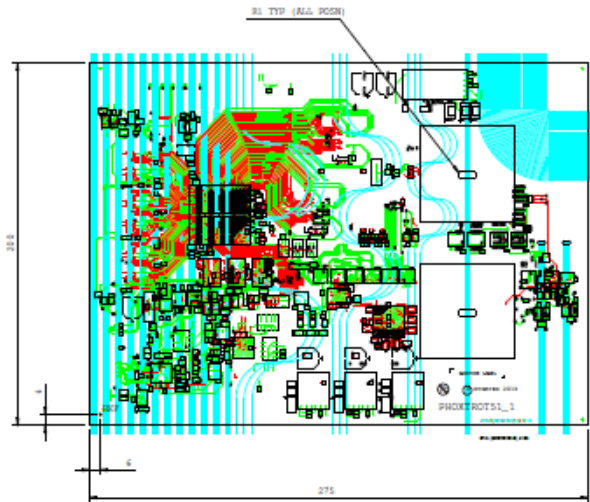

PHOXTROT51_2

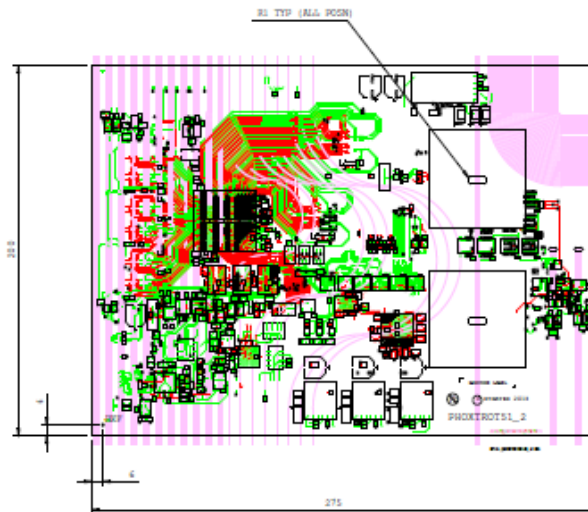

PHOXTROT51_3

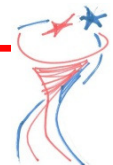
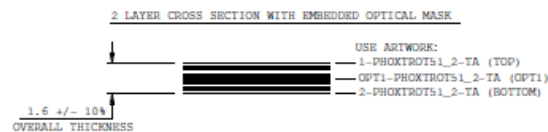
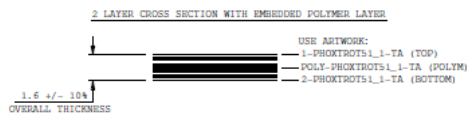
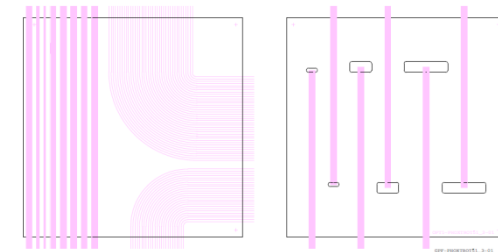

Single-Mode Optical Interconnection Technologies

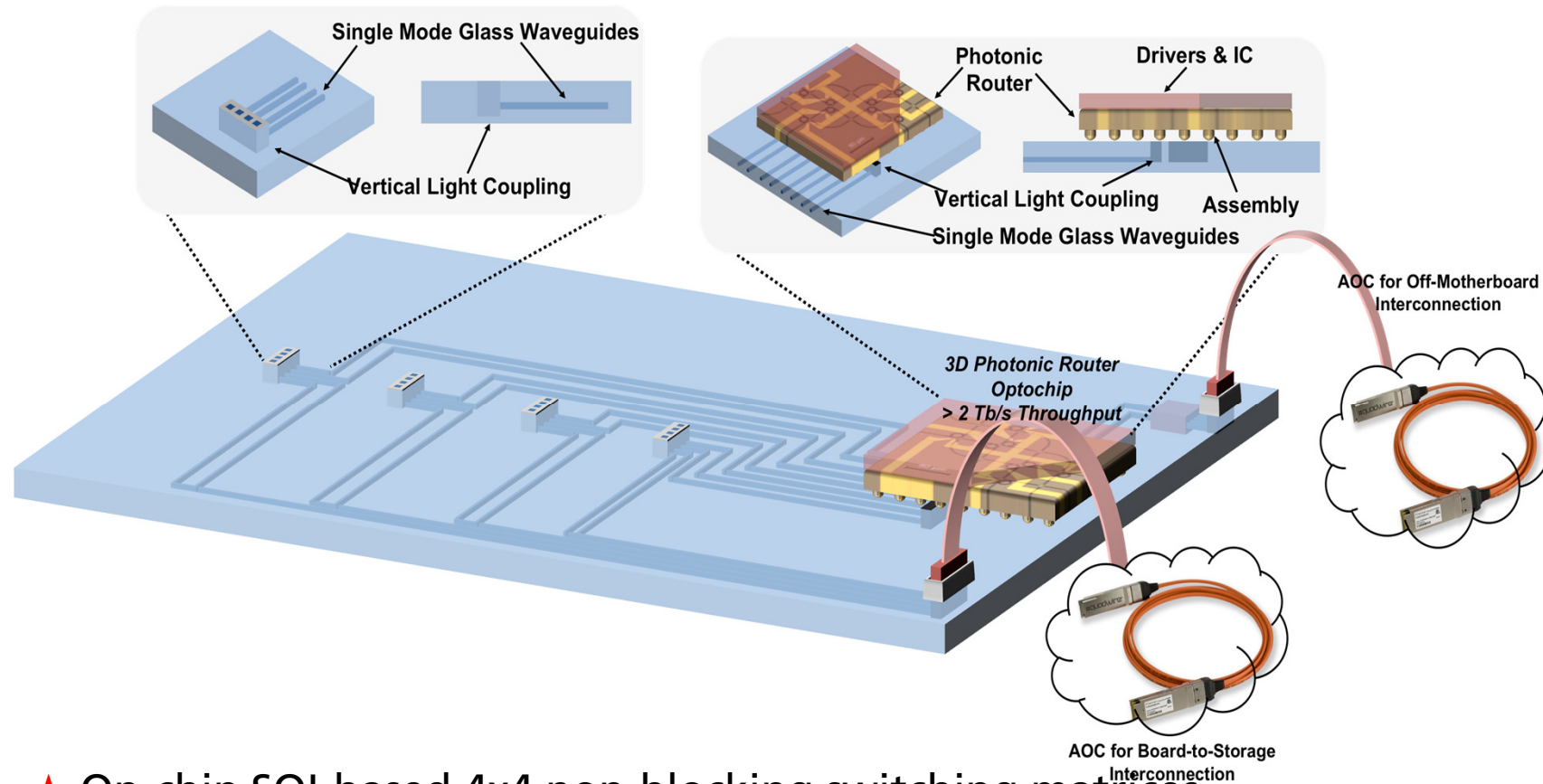

- ★ On-chip SOI-based 4x4 non-blocking switching matrices
- ★ Single-mode polymer and glass embedded waveguides for high-end optical PCBs
- ★ Passive board-level functional circuitry

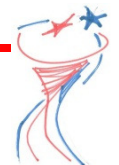

Opto-Chips

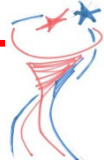
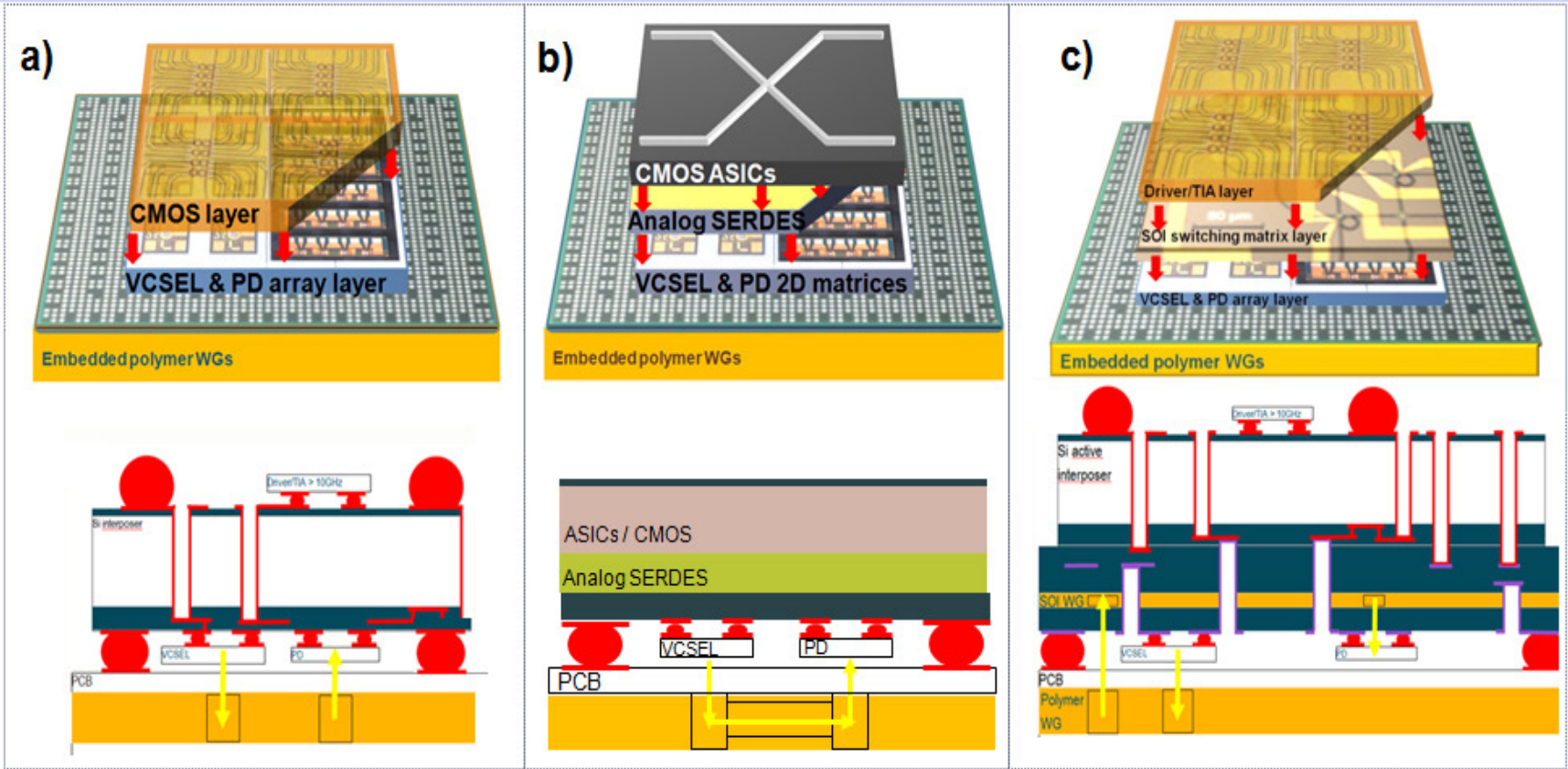

Interfaces

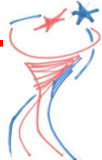
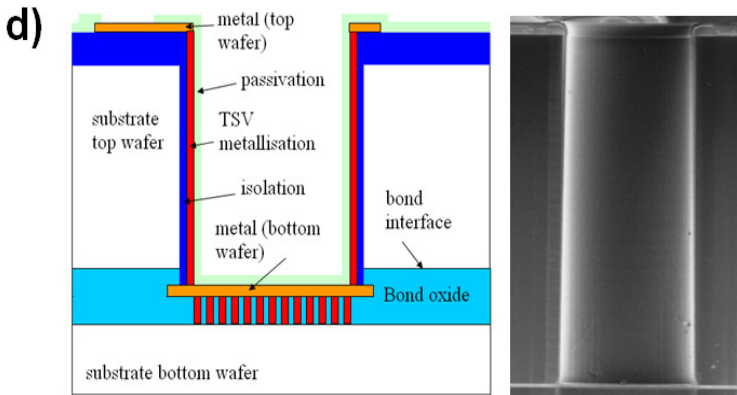
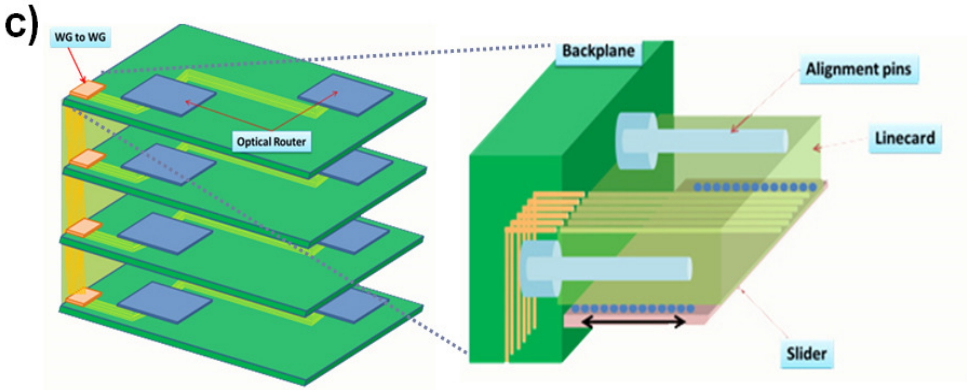
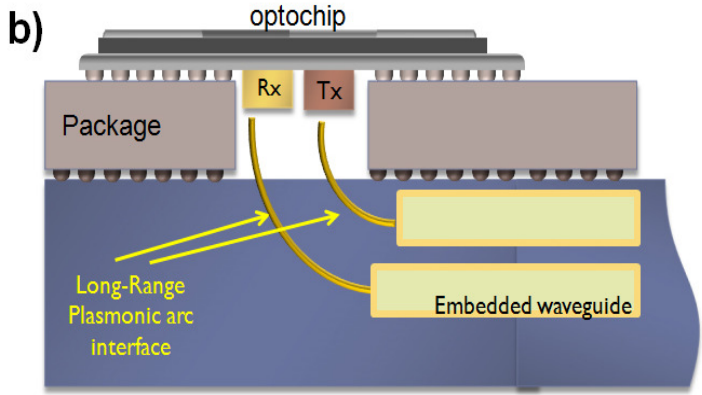
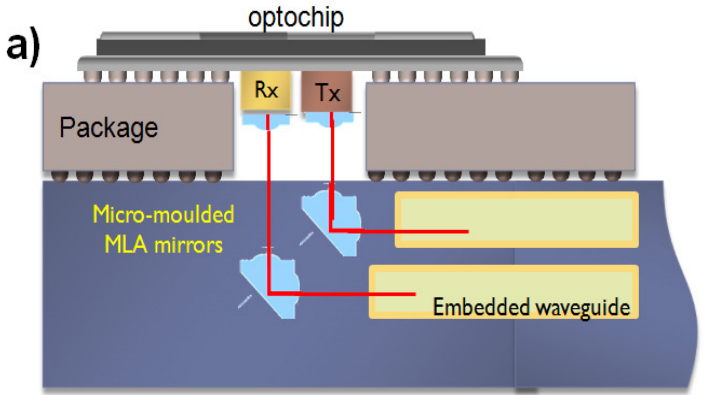

Single-Mode Demonstration Scenario

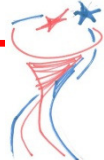
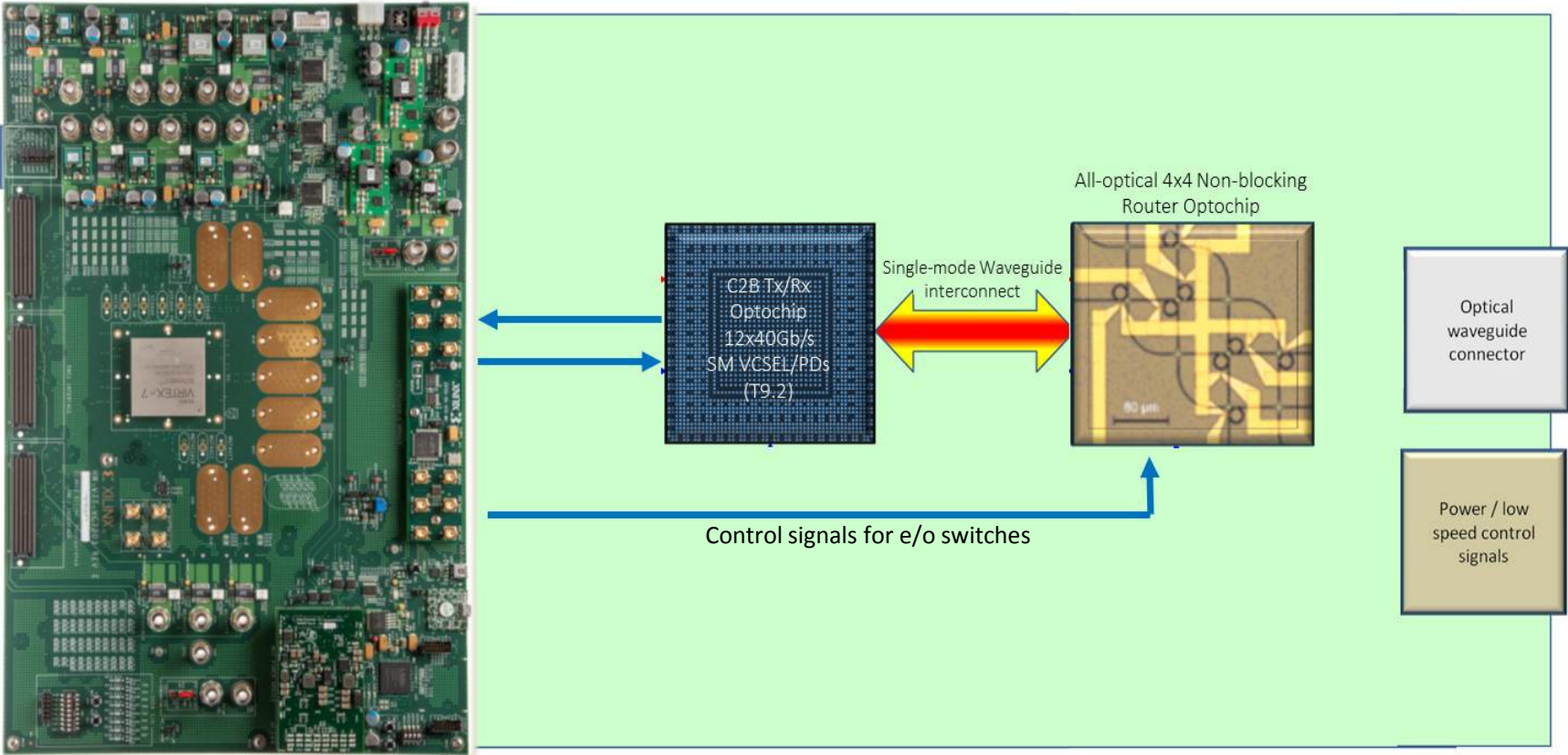

Board-to-Board Optical Interconnection Technologies

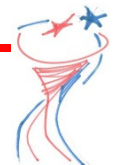
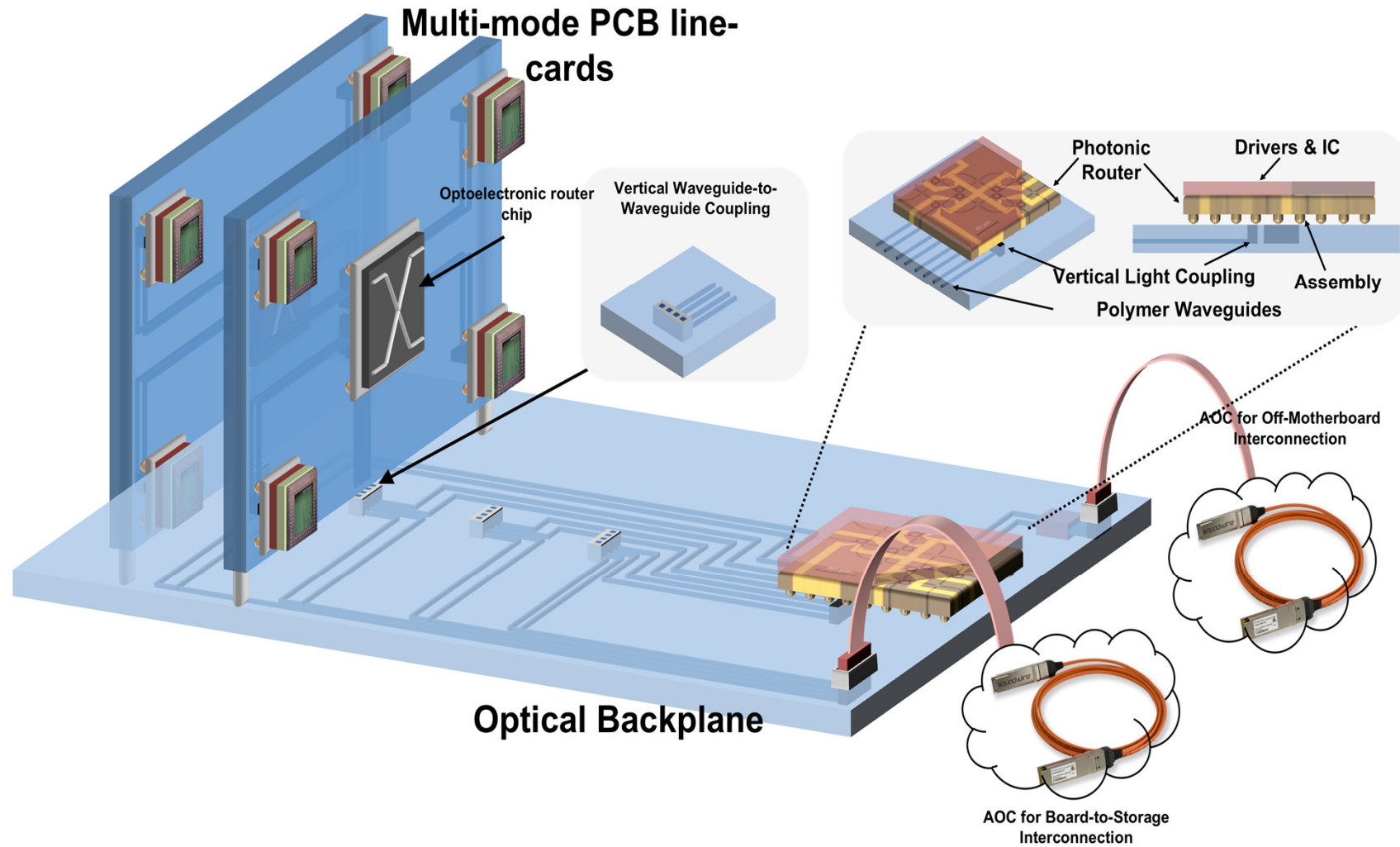

Board-to-Board Demonstration Scenario

Electro-optical backplane – data storage demo

- ★ Multimode waveguide interconnect (double layer)
- ★ Power and low speed electronic control signals
- ★ Provision for 2 daughtercards

Form factor

- ★ 2U or 4U data storage array midplane
- ★ High speed parallel optical links carrying FGA-generated traffic between daughtercards

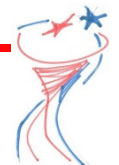
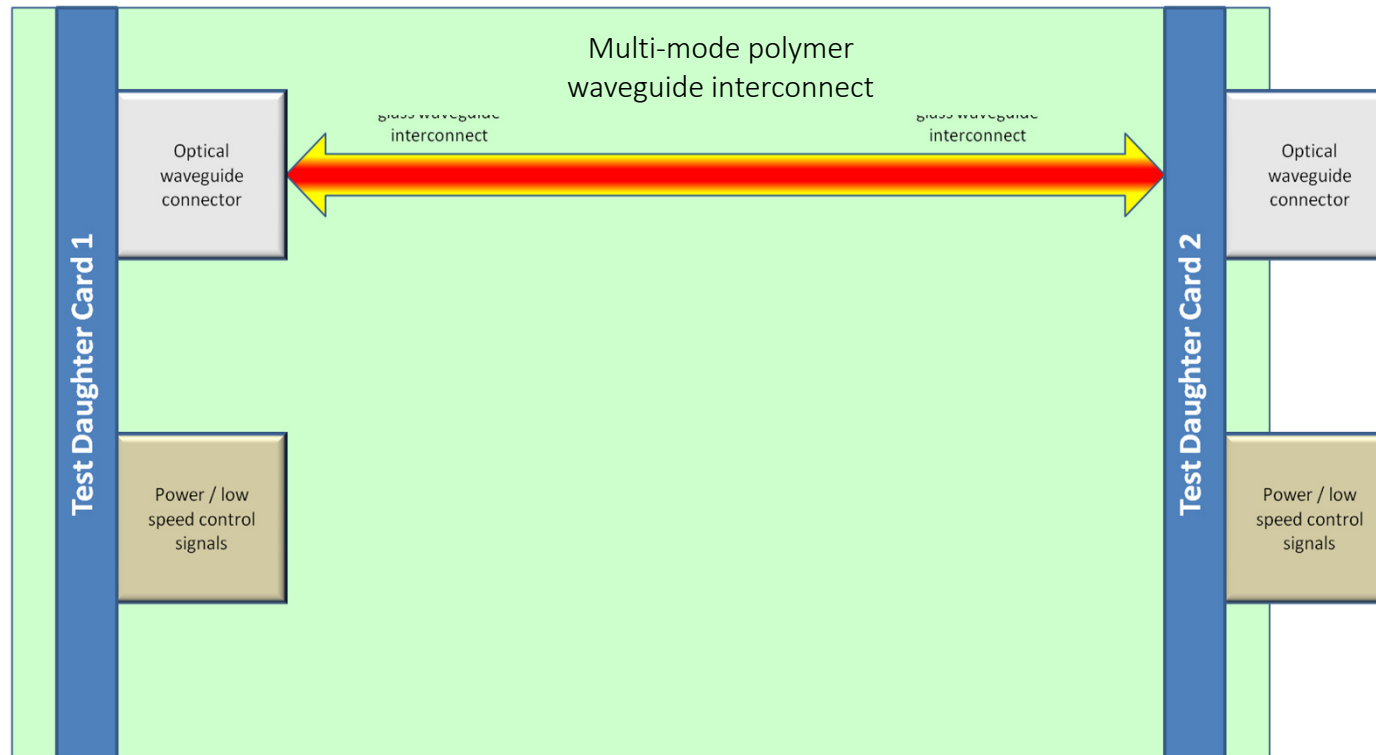

Rack-to-Rack Interconnection Technologies

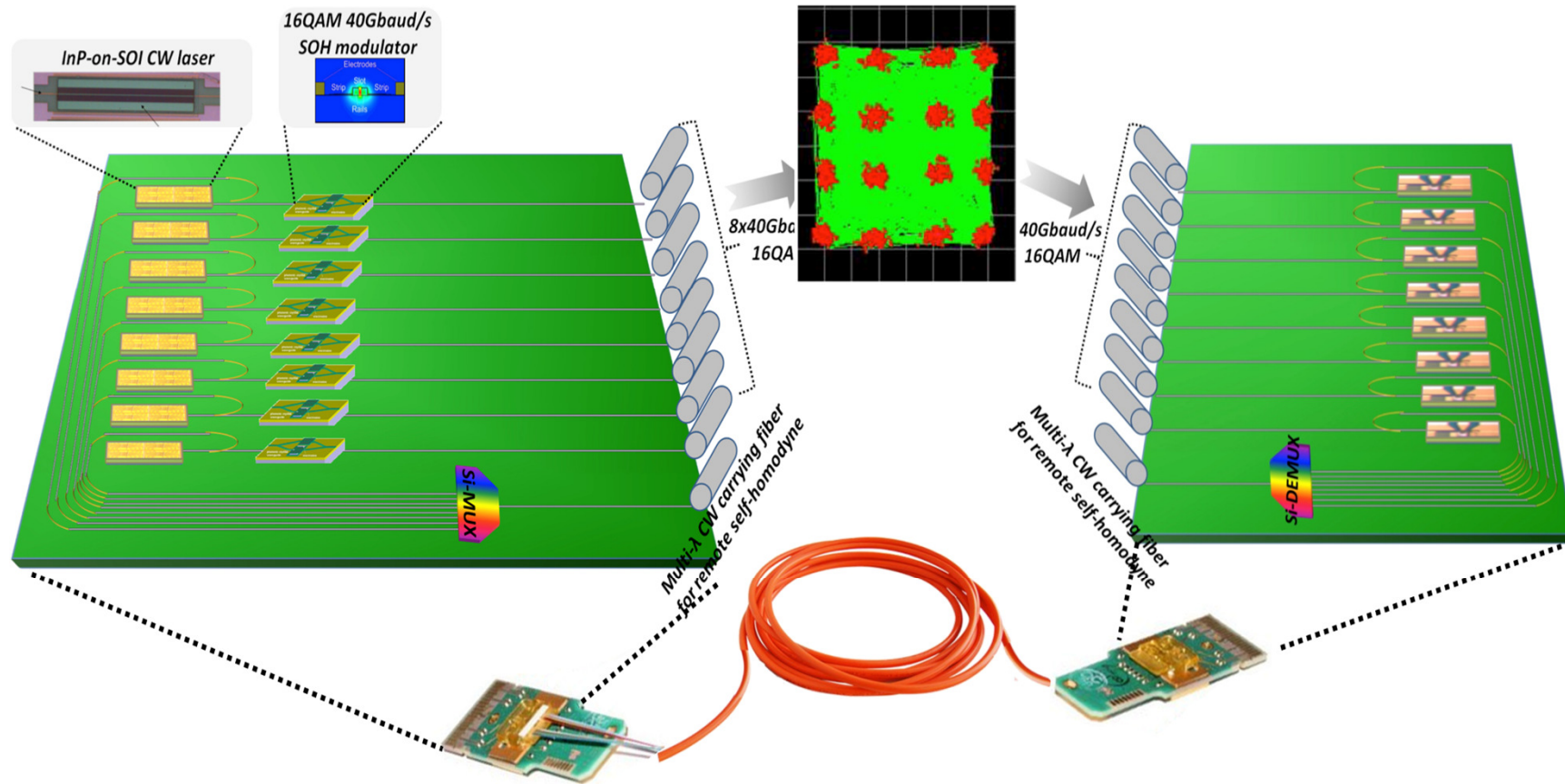

★ Active Optical Cable

★ Exploit advance modulation formats for rack-to-rack interconnection

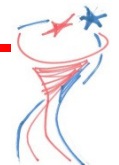

Multimode Polymer Waveguide Development: Process Scaling to large FF's

- ★ Multimode polymer waveguide process compatible with panel-scale HLC PCBs have been developed and demonstrated (TTM technologies)

Multimode waveguides on optical PCBs

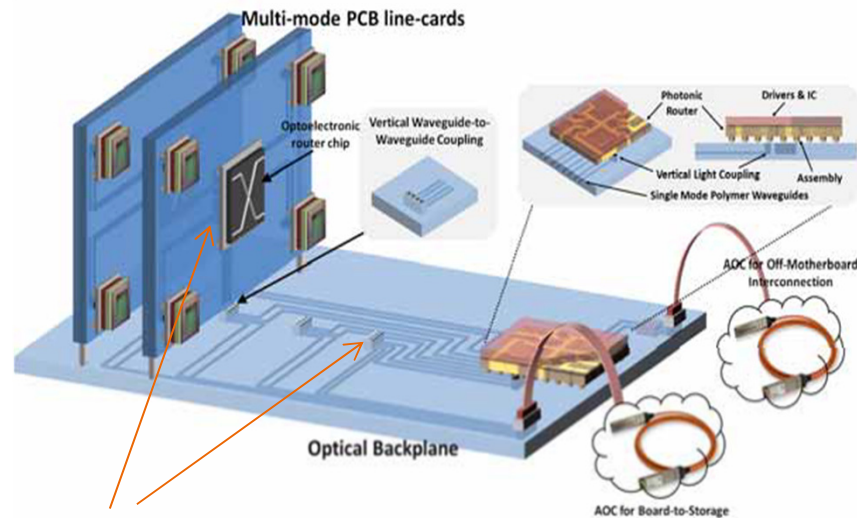

- ★ Multi-mode waveguides on optical line card (chip-to-chip) and optical backplane (board-to-board)

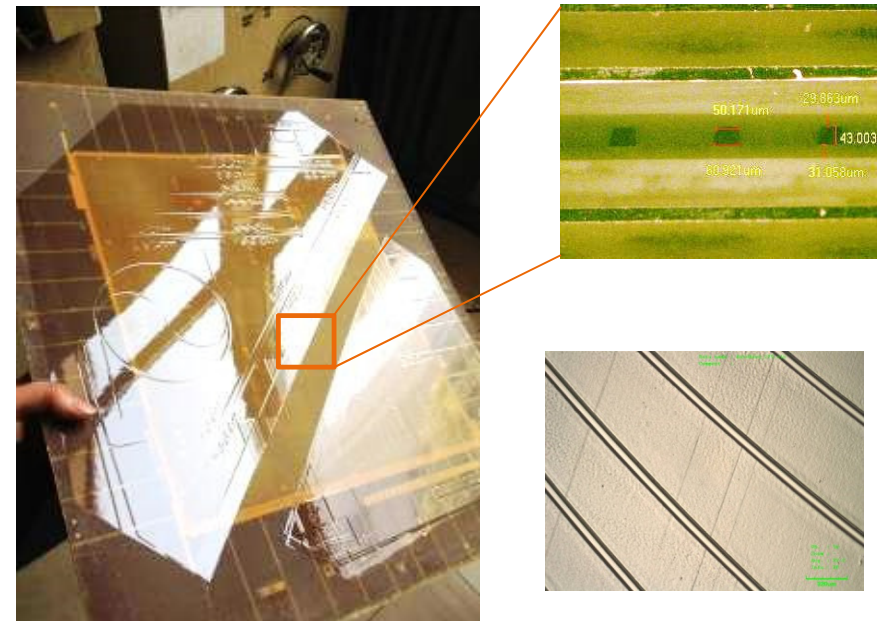

- ★ Single-layer polymer WG process supporting 300x350mm form factor on rigid MLB PCBs established

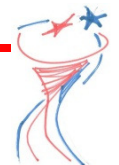

SM Optoboard

- ★ Formation of cavities on Optoboard for direct placement of Optochip on Glass/Optoboard
- ★ Simultaneous creation of an „adhesion promoter layer“ between Arlon and Glass, which also optically offers a cladding with $n < 1.5077$ for SM WG propagation

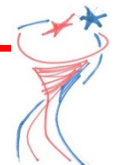
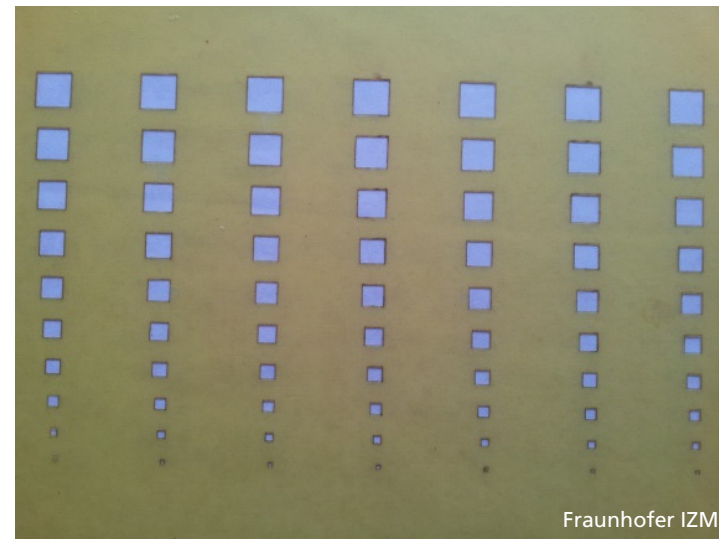
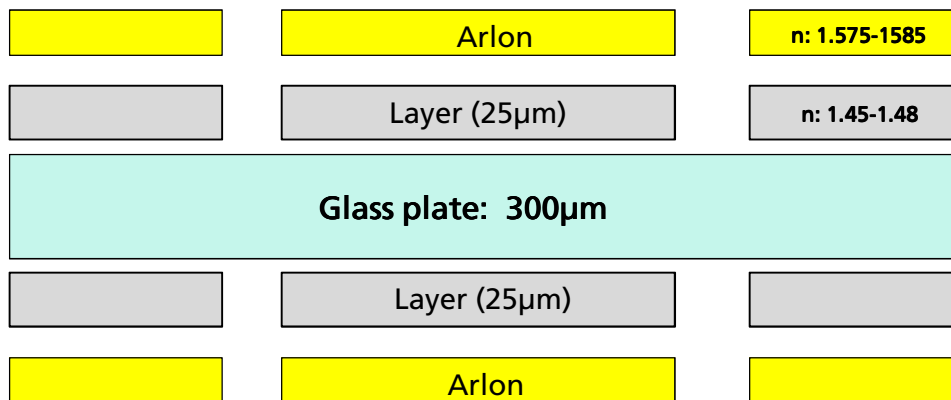

Optoelectronic Routing circuit

Traffic manager chip developed by Compass EOS

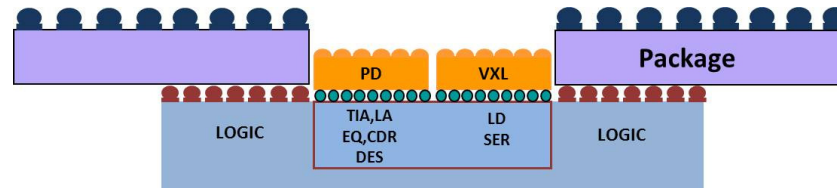
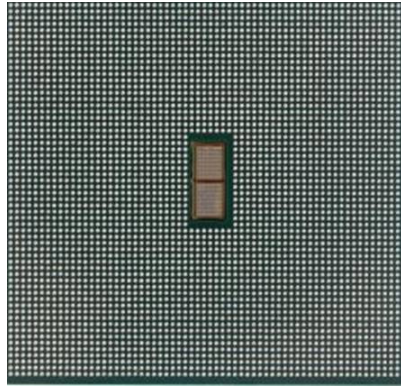

- ★ Aggregate bidi bandwidth 1.34Tb/s with a data density of 64Gb/s/mm²
- ★ 12x14 VCSELs and PDs
- ★ Each link operates at 8Gb/s
- ★ 10.2pJ/bit for each link including all electronics
- ★ BER < 10⁻¹² to 300m with OM3 multimode fiber

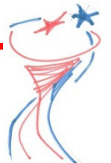

Multimode Coupling Interface

- ★ Development of cavity hole design enabling optical mid-board access I/O (TTM Technologies)

Coupling interface in/out TX/RX

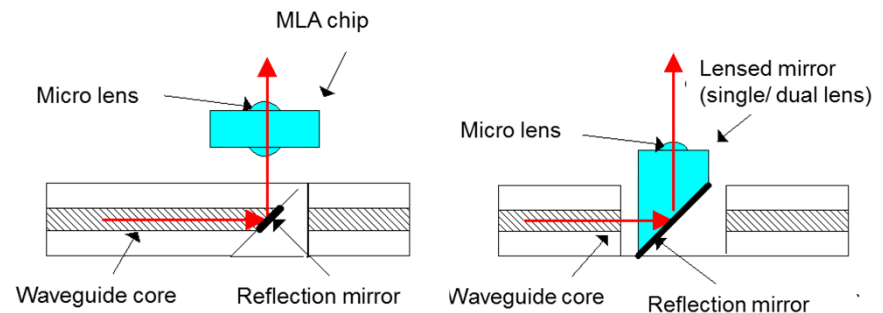
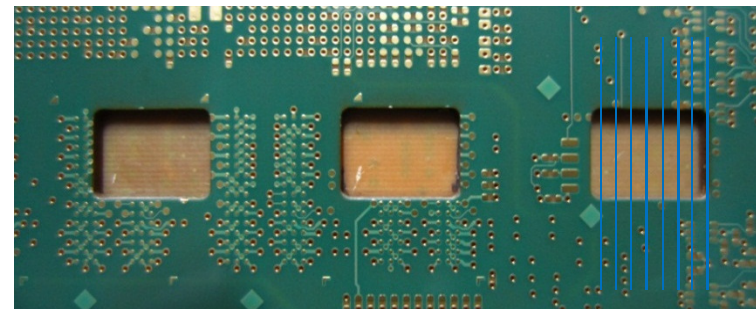
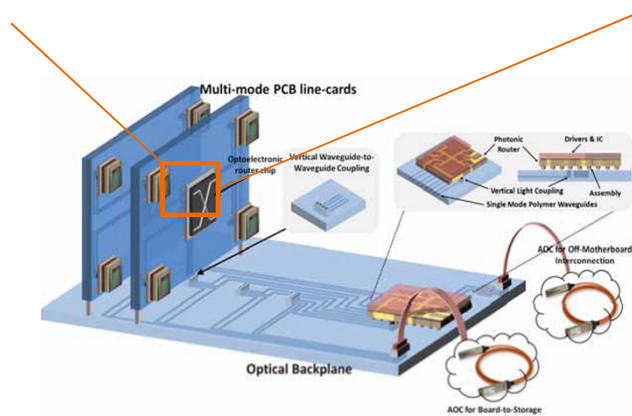
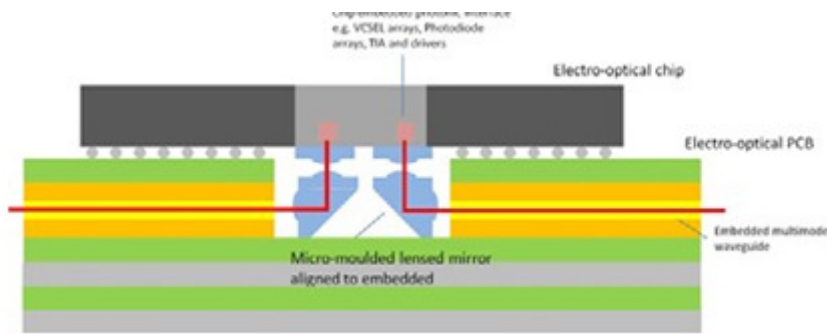

- ★ Optical coupling chip-to-WG (VCSEL/WG, WG/PD) using

- ★ reflector surface built-in WG

- ★ lensed mirror chip component

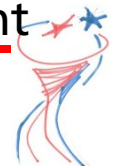

PhoxTroT Roadmap

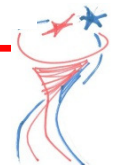
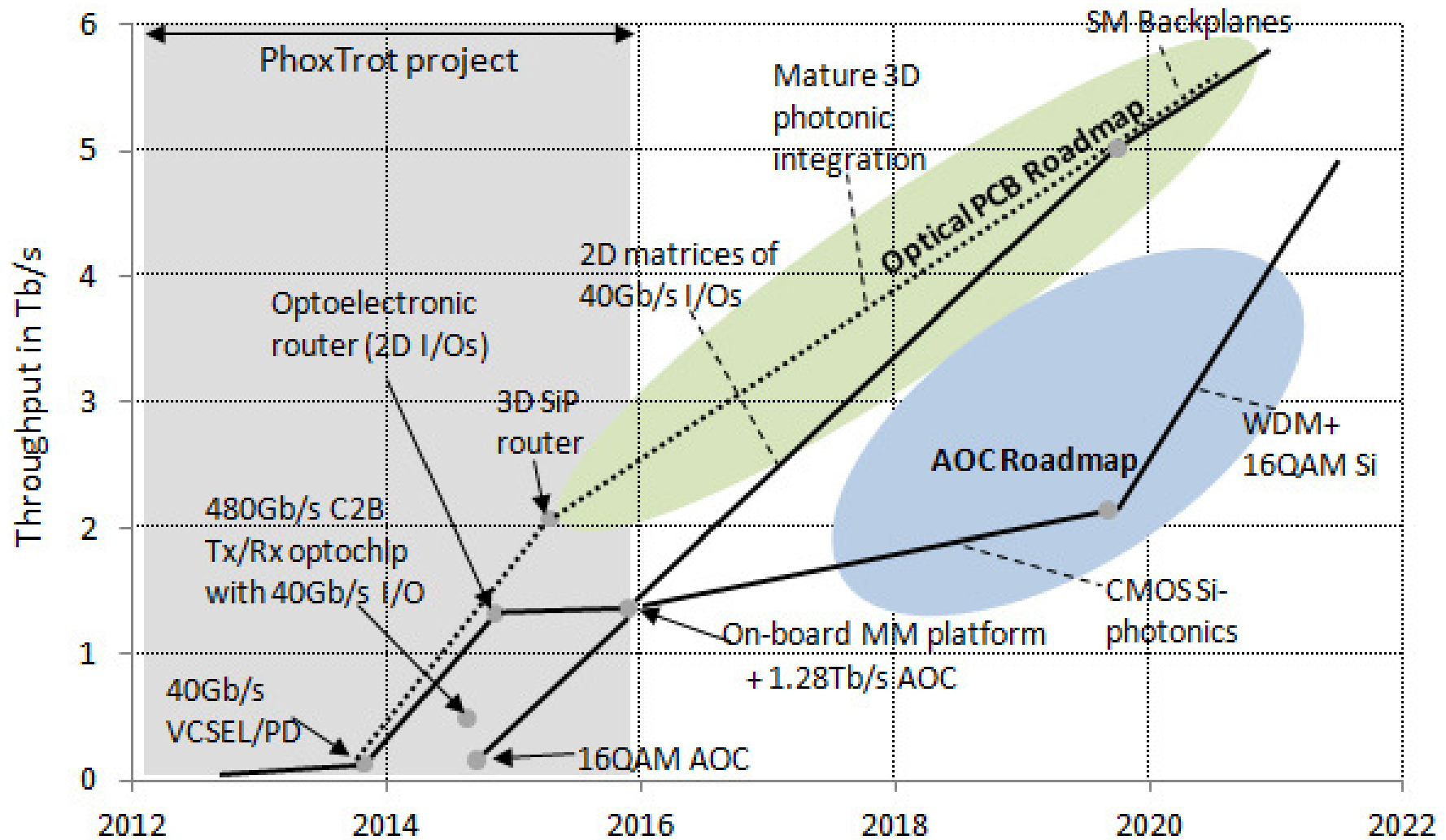

PhoxTroT - Consortium

PhoxTroT brings together the major European industrial and research players in the field.

- ★ Fraunhofer IZM (DE)
- ★ Fraunhofer HHI (DE)
- ★ Vertilas GmbH (DE)
- ★ Xyratex Technology Ltd (UK)
- ★ ams AG (AT)
- ★ TTM Technologies (HK)
- ★ AMO GmbH (DE)
- ★ ICCS/NTUA (EL)
- ★ DAS Photonics SL (ES)
- ★ Phoenix BV (NL)
- ★ CERTH (EL)
- ★ Compass EOS Ltd (IL)
- ★ Bright Photonics BV (NL)
- ★ CTI (EL)
- ★ CNRS-UB (FR)
- ★ CNRS-LPN (FR)
- ★ KIT (DE)
- ★ SDU (DK)
- ★ UPVLC (ES)
- ★ IMEC (BE)
- ★ TE Connectivity (NL)

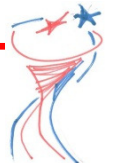

www.phoxtrot.eu

https://twitter.com/PhoxTroT_EU

<https://www.facebook.com/PhoxTroT.eu>

<http://www.linkedin.com/groups/PhoxTroT-Photonic-Interconnects-Data-Centers-4677428>



Program : ICT - Information and Communication Technologies

Project Coordinator:



Dr. Tolga Tekin Photonic & Plasmonic Systems, Fraunhofer for Reliability and Microintegration (IZM)
Tel: +49 30 464 03 639 E-Mail: project.phoxtrot@izm.fraunhofer.de

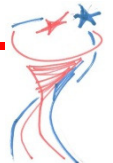

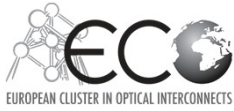

WORKSHOP

Wednesday 25th September 2013, 12:00 – 17:30

Meeting Room: SG21 & SG22



PhoxTroT

Photonics for High-Performance, Low-Cost & Low-Energy
Data Centers, High-Performance Computing Systems;
Terabit/s Optical Interconnect Technologies for On-board,
Board-to-Board, Rack-to-Rack data links

Supported by

Technology Workshop “Optical Interconnect in Data Centers”

18-19 March 2014 Berlin, Germany

Organized by EPIC & PhoxTroT

Held in conjunction with Laser Optics, www.laser-optics-berlin.de

1st European Summer School on “Optical Interconnects”

3-6 June 2014, Thessaloniki, Greece

Co-organized by FP7 PhoxTroT and ECO cluster

